

This is the table of contents and all of chapter one for this textbook.

I think you'll find that it provides excellent instruction, and it includes self-test type questions as you progress through the chapter.

You'll find the answers to the self test questions at the end of the chapter.

For an administrative fee of \$4.97, you can have your own copy of the entire textbook to save on your hard drive and print out.

If you'd like to buy the entire textbook, [Click Here Now](#).

Please contact us at [www.air-conditioning-and-refrigeration-guide.com](http://www.air-conditioning-and-refrigeration-guide.com) if you have any questions.

The textbook begins on the next page.



**NONRESIDENT  
TRAINING  
COURSE**

SEPTEMBER 1998



---

# **Navy Electricity and Electronics Training Series**

## **Module 2—Introduction to Alternating Current and Transformers**

**NAVEDTRA 14174**

**Although the words “he,” “him,” and “his” are used sparingly in this course to enhance communication, they are not intended to be gender driven or to affront or discriminate against anyone.**

# PREFACE

By enrolling in this self-study course, you have demonstrated a desire to improve yourself and the Navy. Remember, however, this self-study course is only one part of the total Navy training program. Practical experience, schools, selected reading, and your desire to succeed are also necessary to successfully round out a fully meaningful training program.

**COURSE OVERVIEW:** To introduce the student to the subject of Alternating Current and Transformers who needs such a background in accomplishing daily work and/or in preparing for further study.

**THE COURSE:** This self-study course is organized into subject matter areas, each containing learning objectives to help you determine what you should learn along with text and illustrations to help you understand the information. The subject matter reflects day-to-day requirements and experiences of personnel in the rating or skill area. It also reflects guidance provided by Enlisted Community Managers (ECMs) and other senior personnel, technical references, instructions, etc., and either the occupational or naval standards, which are listed in the *Manual of Navy Enlisted Manpower Personnel Classifications and Occupational Standards*, NAVPERS 18068.

**THE QUESTIONS:** The questions that appear in this course are designed to help you understand the material in the text.

**VALUE:** In completing this course, you will improve your military and professional knowledge. Importantly, it can also help you study for the Navy-wide advancement in rate examination. If you are studying and discover a reference in the text to another publication for further information, look it up.

*1998 Edition Prepared by  
DSC Ray A. Jackson*

Published by  
NAVAL EDUCATION AND TRAINING  
PROFESSIONAL DEVELOPMENT  
AND TECHNOLOGY CENTER

**NAVSUP Logistics Tracking Number  
0504-LP-026-8270**

## **Sailor's Creed**

“I am a United States Sailor.

I will support and defend the Constitution of the United States of America and I will obey the orders of those appointed over me.

I represent the fighting spirit of the Navy and those who have gone before me to defend freedom and democracy around the world.

I proudly serve my country's Navy combat team with honor, courage and commitment.

I am committed to excellence and the fair treatment of all.”

# TABLE OF CONTENTS

<b>CHAPTER</b>	<b>PAGE</b>
1. Concepts of Alternating Current .....	1-1
2. Inductance .....	2-1
3. Capacitance .....	3-1
4. Inductive and Capacitive Reactance.....	4-1
5. Transformers .....	5-1
 <b>APPENDIX</b>	
I. Glossary.....	AI-1
II. Greek Alphabet.....	AII-1
III. Square and Square Roots.....	AIII-1
IV. Useful AC Formulas.....	AIV-1
V. Trigonometric Functions .....	AV-1
VI. Trigonometric Tables .....	AVI-1
<b>INDEX</b> .....	<b>INDEX-1</b>

# NAVY ELECTRICITY AND ELECTRONICS TRAINING SERIES

The Navy Electricity and Electronics Training Series (NEETS) was developed for use by personnel in many electrical- and electronic-related Navy ratings. Written by, and with the advice of, senior technicians in these ratings, this series provides beginners with fundamental electrical and electronic concepts through self-study. The presentation of this series is not oriented to any specific rating structure, but is divided into modules containing related information organized into traditional paths of instruction.

The series is designed to give small amounts of information that can be easily digested before advancing further into the more complex material. For a student just becoming acquainted with electricity or electronics, it is highly recommended that the modules be studied in their suggested sequence. While there is a listing of NEETS by module title, the following brief descriptions give a quick overview of how the individual modules flow together.

**Module 1, *Introduction to Matter, Energy, and Direct Current***, introduces the course with a short history of electricity and electronics and proceeds into the characteristics of matter, energy, and direct current (dc). It also describes some of the general safety precautions and first-aid procedures that should be common knowledge for a person working in the field of electricity. Related safety hints are located throughout the rest of the series, as well.

**Module 2, *Introduction to Alternating Current and Transformers***, is an introduction to alternating current (ac) and transformers, including basic ac theory and fundamentals of electromagnetism, inductance, capacitance, impedance, and transformers.

**Module 3, *Introduction to Circuit Protection, Control, and Measurement***, encompasses circuit breakers, fuses, and current limiters used in circuit protection, as well as the theory and use of meters as electrical measuring devices.

**Module 4, *Introduction to Electrical Conductors, Wiring Techniques, and Schematic Reading***, presents conductor usage, insulation used as wire covering, splicing, termination of wiring, soldering, and reading electrical wiring diagrams.

**Module 5, *Introduction to Generators and Motors***, is an introduction to generators and motors, and covers the uses of ac and dc generators and motors in the conversion of electrical and mechanical energies.

**Module 6, *Introduction to Electronic Emission, Tubes, and Power Supplies***, ties the first five modules together in an introduction to vacuum tubes and vacuum-tube power supplies.

**Module 7, *Introduction to Solid-State Devices and Power Supplies***, is similar to module 6, but it is in reference to solid-state devices.

**Module 8, *Introduction to Amplifiers***, covers amplifiers.

**Module 9, *Introduction to Wave-Generation and Wave-Shaping Circuits***, discusses wave generation and wave-shaping circuits.

**Module 10, *Introduction to Wave Propagation, Transmission Lines, and Antennas***, presents the characteristics of wave propagation, transmission lines, and antennas.

**Module 11**, *Microwave Principles*, explains microwave oscillators, amplifiers, and waveguides.

**Module 12**, *Modulation Principles*, discusses the principles of modulation.

**Module 13**, *Introduction to Number Systems and Logic Circuits*, presents the fundamental concepts of number systems, Boolean algebra, and logic circuits, all of which pertain to digital computers.

**Module 14**, *Introduction to Microelectronics*, covers microelectronics technology and miniature and microminiature circuit repair.

**Module 15**, *Principles of Synchros, Servos, and Gyros*, provides the basic principles, operations, functions, and applications of synchro, servo, and gyro mechanisms.

**Module 16**, *Introduction to Test Equipment*, is an introduction to some of the more commonly used test equipments and their applications.

**Module 17**, *Radio-Frequency Communications Principles*, presents the fundamentals of a radio-frequency communications system.

**Module 18**, *Radar Principles*, covers the fundamentals of a radar system.

**Module 19**, *The Technician's Handbook*, is a handy reference of commonly used general information, such as electrical and electronic formulas, color coding, and naval supply system data.

**Module 20**, *Master Glossary*, is the glossary of terms for the series.

**Module 21**, *Test Methods and Practices*, describes basic test methods and practices.

**Module 22**, *Introduction to Digital Computers*, is an introduction to digital computers.

**Module 23**, *Magnetic Recording*, is an introduction to the use and maintenance of magnetic recorders and the concepts of recording on magnetic tape and disks.

**Module 24**, *Introduction to Fiber Optics*, is an introduction to fiber optics.

Embedded questions are inserted throughout each module, except for modules 19 and 20, which are reference books. If you have any difficulty in answering any of the questions, restudy the applicable section.

Although an attempt has been made to use simple language, various technical words and phrases have necessarily been included. Specific terms are defined in Module 20, *Master Glossary*.

Considerable emphasis has been placed on illustrations to provide a maximum amount of information. In some instances, a knowledge of basic algebra may be required.

Assignments are provided for each module, with the exceptions of Module 19, *The Technician's Handbook*; and Module 20, *Master Glossary*. Course descriptions and ordering information are in NAVEDTRA 12061, *Catalog of Nonresident Training Courses*.

Throughout the text of this course and while using technical manuals associated with the equipment you will be working on, you will find the below notations at the end of some paragraphs. The notations are used to emphasize that safety hazards exist and care must be taken or observed.

### **WARNING**

AN OPERATING PROCEDURE, PRACTICE, OR CONDITION, ETC., WHICH MAY RESULT IN INJURY OR DEATH IF NOT CAREFULLY OBSERVED OR FOLLOWED.

### **CAUTION**

AN OPERATING PROCEDURE, PRACTICE, OR CONDITION, ETC., WHICH MAY RESULT IN DAMAGE TO EQUIPMENT IF NOT CAREFULLY OBSERVED OR FOLLOWED.

### **NOTE**

An operating procedure, practice, or condition, etc., which is essential to emphasize.

# INSTRUCTIONS FOR TAKING THE COURSE

## ASSIGNMENTS

The text pages that you are to study are listed at the beginning of each assignment. Study these pages carefully before attempting to answer the questions. Pay close attention to tables and illustrations and read the learning objectives. The learning objectives state what you should be able to do after studying the material. Answering the questions correctly helps you accomplish the objectives.

## SELECTING YOUR ANSWERS

Read each question carefully, then select the BEST answer. You may refer freely to the text. The answers must be the result of your own work and decisions. You are prohibited from referring to or copying the answers of others and from giving answers to anyone else taking the course.

## SUBMITTING YOUR ASSIGNMENTS

To have your assignments graded, you must be enrolled in the course with the Nonresident Training Course Administration Branch at the Naval Education and Training Professional Development and Technology Center (NETPDTC). Following enrollment, there are two ways of having your assignments graded: (1) use the Internet to submit your assignments as you complete them, or (2) send all the assignments at one time by mail to NETPDTC.

**Grading on the Internet:** Advantages to Internet grading are:

- you may submit your answers as soon as you complete an assignment, and
- you get your results faster; usually by the next working day (approximately 24 hours).

In addition to receiving grade results for each assignment, you will receive course completion confirmation once you have completed all the

assignments. To submit your assignment answers via the Internet, go to:

<http://courses.cnet.navy.mil>

**Grading by Mail:** When you submit answer sheets by mail, send all of your assignments at one time. Do NOT submit individual answer sheets for grading. Mail all of your assignments in an envelope, which you either provide yourself or obtain from your nearest Educational Services Officer (ESO). Submit answer sheets to:

COMMANDING OFFICER  
NETPDTC N331  
6490 SAUFLEY FIELD ROAD  
PENSACOLA FL 32559-5000

**Answer Sheets:** All courses include one “scannable” answer sheet for each assignment. These answer sheets are preprinted with your SSN, name, assignment number, and course number. Explanations for completing the answer sheets are on the answer sheet.

**Do not use answer sheet reproductions:** Use only the original answer sheets that we provide—reproductions will not work with our scanning equipment and cannot be processed.

Follow the instructions for marking your answers on the answer sheet. Be sure that blocks 1, 2, and 3 are filled in correctly. This information is necessary for your course to be properly processed and for you to receive credit for your work.

## COMPLETION TIME

Courses must be completed within 12 months from the date of enrollment. This includes time required to resubmit failed assignments.

## **PASS/FAIL ASSIGNMENT PROCEDURES**

If your overall course score is 3.2 or higher, you will pass the course and will not be required to resubmit assignments. Once your assignments have been graded you will receive course completion confirmation.

If you receive less than a 3.2 on any assignment and your overall course score is below 3.2, you will be given the opportunity to resubmit failed assignments. **You may resubmit failed assignments only once.** Internet students will receive notification when they have failed an assignment--they may then resubmit failed assignments on the web site. Internet students may view and print results for failed assignments from the web site. Students who submit by mail will receive a failing result letter and a new answer sheet for resubmission of each failed assignment.

## **COMPLETION CONFIRMATION**

After successfully completing this course, you will receive a letter of completion.

## **ERRATA**

Errata are used to correct minor errors or delete obsolete information in a course. Errata may also be used to provide instructions to the student. If a course has an errata, it will be included as the first page(s) after the front cover. Errata for all courses can be accessed and viewed/downloaded at:

<http://www.advancement.cnet.navy.mil>

## **STUDENT FEEDBACK QUESTIONS**

We value your suggestions, questions, and criticisms on our courses. If you would like to communicate with us regarding this course, we encourage you, if possible, to use e-mail. If you write or fax, please use a copy of the Student Comment form that follows this page.

## **For subject matter questions:**

E-mail: n315.products@cnet.navy.mil  
Phone: Comm: (850) 452-1001, ext. 1728  
DSN: 922-1001, ext. 1728  
FAX: (850) 452-1370  
(Do not fax answer sheets.)  
Address: COMMANDING OFFICER  
NETPDTC N315  
6490 SAUFLEY FIELD ROAD  
PENSACOLA FL 32509-5237

## **For enrollment, shipping, grading, or completion letter questions**

E-mail: fleetservices@cnet.navy.mil  
Phone: Toll Free: 877-264-8583  
Comm: (850) 452-1511/1181/1859  
DSN: 922-1511/1181/1859  
FAX: (850) 452-1370  
(Do not fax answer sheets.)  
Address: COMMANDING OFFICER  
NETPDTC N331  
6490 SAUFLEY FIELD ROAD  
PENSACOLA FL 32559-5000

## **NAVAL RESERVE RETIREMENT CREDIT**

If you are a member of the Naval Reserve, you will receive retirement points if you are authorized to receive them under current directives governing retirement of Naval Reserve personnel. For Naval Reserve retirement, this course is evaluated at 10 points. (Refer to *Administrative Procedures for Naval Reservists on Inactive Duty*, BUPERSINST 1001.39, for more information about retirement points.)

## Student Comments

**Course Title:** NEETS Module 2  
Introduction to Alternating Current and Transformers

**NAVEDTRA:** 14174 **Date:** \_\_\_\_\_

**We need some information about you:**

Rate/Rank and Name: \_\_\_\_\_ SSN: \_\_\_\_\_ Command/Unit \_\_\_\_\_

Street Address: \_\_\_\_\_ City: \_\_\_\_\_ State/FPO: \_\_\_\_\_ Zip \_\_\_\_\_

**Your comments, suggestions, etc.:**

<p><b>Privacy Act Statement:</b> Under authority of Title 5, USC 301, information regarding your military status is requested in processing your comments and in preparing a reply. This information will not be divulged without written authorization to anyone other than those within DOD for official use in determining performance.</p>
--

NETPDTC 1550/41 (Rev 4-00)



# CHAPTER 1

## CONCEPTS OF ALTERNATING CURRENT

### LEARNING OBJECTIVES

Upon completion of this chapter you will be able to:

1. State the differences between ac and dc voltage and current.
2. State the advantages of ac power transmission over dc power transmission.
3. State the "left-hand rule" for a conductor.
4. State the relationship between current and magnetism.
5. State the methods by which ac power can be generated.
6. State the relationship between frequency, period, time, and wavelength.
7. Compute peak-to-peak, instantaneous, effective, and average values of voltage and current.
8. Compute the phase difference between sine waves.

### CONCEPTS OF ALTERNATING CURRENT

All of your study thus far has been with direct current (dc), that is, current which does not change direction. However, as you saw in module 1 and will see later in this module, a coil rotating in a magnetic field actually generates a current which regularly changes direction. This current is called ALTERNATING CURRENT or ac.

### AC AND DC

Alternating current is current which constantly changes in amplitude, and which reverses direction at regular intervals. You learned previously that direct current flows only in one direction, and that the amplitude of current is determined by the number of electrons flowing past a point in a circuit in one second. If, for example, a coulomb of electrons moves past a point in a wire in one second and all of the electrons are moving in the same direction, the amplitude of direct current in the wire is one ampere. Similarly, if half a coulomb of electrons moves in one direction past a point in the wire in half a second, then reverses direction and moves past the same point in the opposite direction during the next half-second, a total of one coulomb of electrons passes the point in one second. The amplitude of the alternating current is one ampere. The preceding comparison of dc and ac as illustrated. Notice that one white arrow plus one striped arrow comprise one coulomb.

## COMPARING DC & AC CURRENT FLOW IN A WIRE

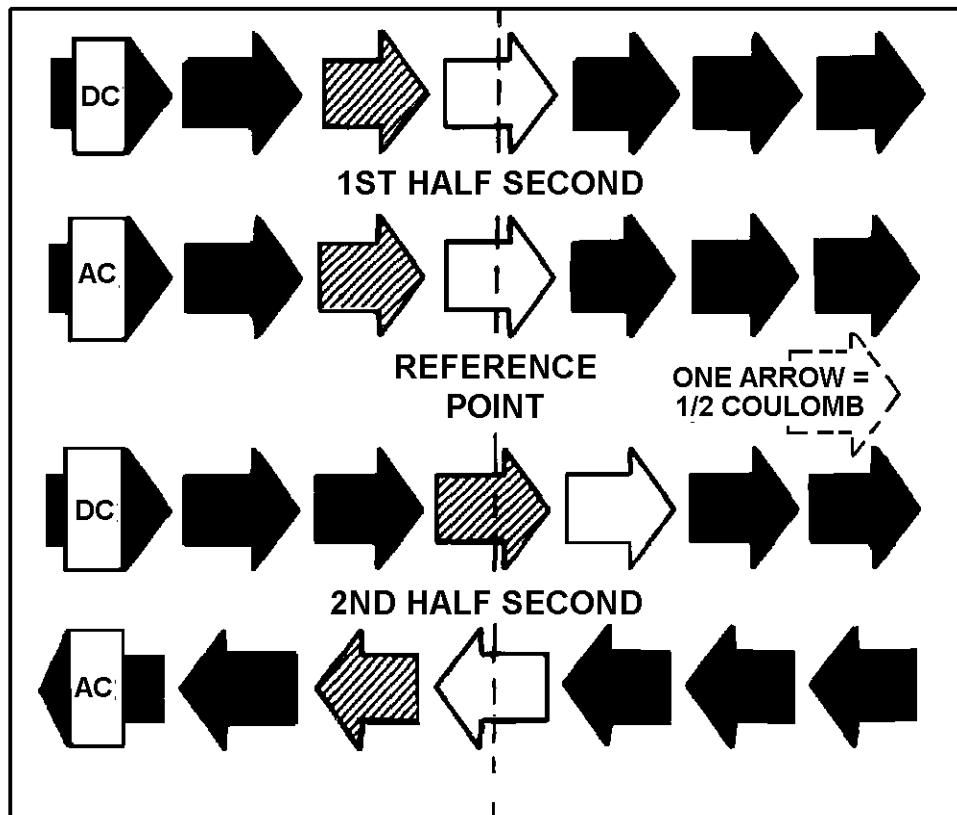

Q1. Define direct current.

Q2. Define alternating current.

## DISADVANTAGES OF DC COMPARED TO AC

When commercial use of electricity became wide-spread in the United States, certain disadvantages in using direct current in the home became apparent. If a commercial direct-current system is used, the voltage must be generated at the level (amplitude or value) required by the load. To properly light a 240-volt lamp, for example, the dc generator must deliver 240 volts. If a 120-volt lamp is to be supplied power from the 240-volt generator, a resistor or another 120-volt lamp must be placed in series with the 120-volt lamp to drop the extra 120 volts. When the resistor is used to reduce the voltage, an amount of power equal to that consumed by the lamp is wasted.

Another disadvantage of the direct-current system becomes evident when the direct current (I) from the generating station must be transmitted a long distance over wires to the consumer. When this happens, a large amount of power is lost due to the resistance (R) of the wire. The power loss is equal to  $I^2R$ . However, this loss can be greatly reduced if the power is transmitted over the lines at a very high voltage level and a low current level. This is not a practical solution to the power loss in the dc system since the load would then have to be operated at a dangerously high voltage. Because of the disadvantages related to transmitting and using direct current, practically all modern commercial electric power companies generate and distribute alternating current (ac).

Unlike direct voltages, alternating voltages can be stepped up or down in amplitude by a device called a TRANSFORMER. (The transformer will be explained later in this module.) Use of the transformer permits efficient transmission of electrical power over long-distance lines. At the electrical power station, the transformer output power is at high voltage and low current levels. At the consumer end of the transmission lines, the voltage is stepped down by a transformer to the value required by the load. Due to its inherent advantages and versatility, alternating current has replaced direct current in all but a few commercial power distribution systems.

- Q3. What is a disadvantage of a direct-current system with respect to supply voltage?
- Q4. What disadvantage of a direct current is due to the resistance of the transmission wires?
- Q5. What kind of electrical current is used in most modern power distribution systems?

### VOLTAGE WAVEFORMS

You now know that there are two types of current and voltage, that is, direct current and voltage and alternating current and voltage. If a graph is constructed showing the amplitude of a dc voltage across the terminals of a battery with respect to time, it will appear in figure 1-1 view A. The dc voltage is shown to have a constant amplitude. Some voltages go through periodic changes in amplitude like those shown in figure 1-1 view B. The pattern which results when these changes in amplitude with respect to time are plotted on graph paper is known as a WAVEFORM. Figure 1-1 view B shows some of the common electrical waveforms. Of those illustrated, the sine wave will be dealt with most often.

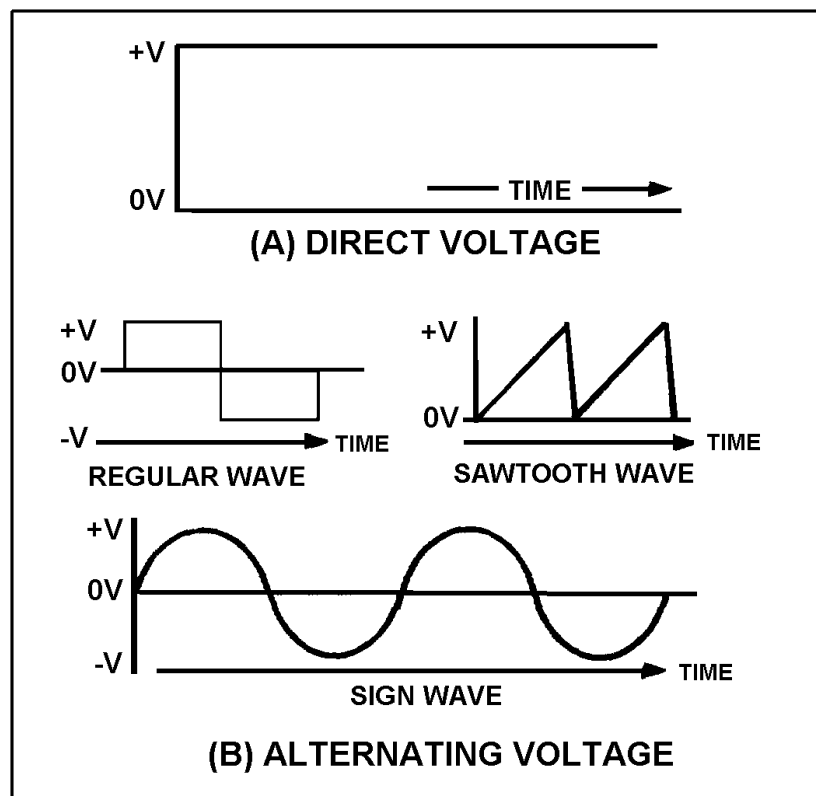

Figure 1-1.—Voltage waveforms: (A) Direct voltage; (B) Alternating voltage.

## ELECTROMAGNETISM

The sine wave illustrated in figure 1-1 view B is a plot of a current which changes amplitude and direction. Although there are several ways of producing this current, the method based on the principles of electromagnetic induction is by far the easiest and most common method in use.

The fundamental theories concerning simple magnets and magnetism were discussed in Module 1, but how magnetism can be used to produce electricity was only briefly mentioned. This module will give you a more in-depth study of magnetism. The main points that will be explained are how magnetism is affected by an electric current and, conversely, how electricity is affected by magnetism. This general subject area is most often referred to as ELECTROMAGNETISM. To properly understand electricity you must first become familiar with the relationships between magnetism and electricity. For example, you must know that:

- An electric current always produces some form of magnetism.
- The most commonly used means for producing or using electricity involves magnetism.
- The peculiar behavior of electricity under certain conditions is caused by magnetic influences.

## MAGNETIC FIELDS

In 1819 Hans Christian Oersted, a Danish physicist, found that a definite relationship exists between magnetism and electricity. He discovered that an electric current is always accompanied by certain magnetic effects and that these effects obey definite laws.

### MAGNETIC FIELD AROUND A CURRENT-CARRYING CONDUCTOR

If a compass is placed in the vicinity of a current-carrying conductor, the compass needle will align itself at right angles to the conductor, thus indicating the presence of a magnetic force. You can demonstrate the presence of this force by using the arrangement illustrated in figure 1-2. In both (A) and (B) of the figure, current flows in a vertical conductor through a horizontal piece of cardboard. You can determine the direction of the magnetic force produced by the current by placing a compass at various points on the cardboard and noting the compass needle deflection. The direction of the magnetic force is assumed to be the direction in which the north pole of the compass points.

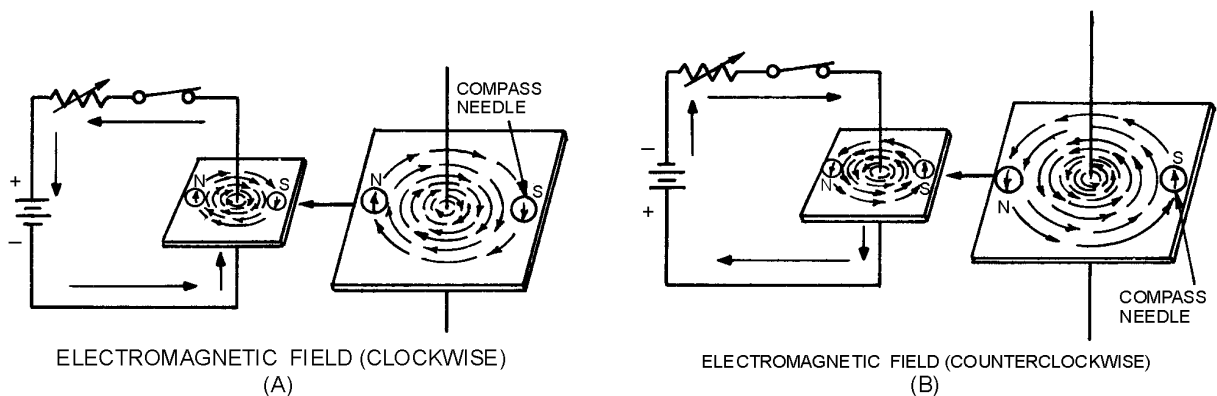

Figure 1-2.—Magnetic field around a current-carrying conductor.

In figure 1-2 (A), the needle deflections show that a magnetic field exists in circular form around the conductor. When the current flows upward (see figure 1-2(A)), the direction of the field is clockwise, as viewed from the top. However, if you reverse the polarity of the battery so that the current flows downward (see figure 1-2(B)), the direction of the field is counterclockwise.

The relation between the direction of the magnetic lines of force around a conductor and the direction of electron current flow in the conductor may be determined by means of the **LEFT-HAND RULE FOR A CONDUCTOR**: if you grasp the conductor in your left hand with the thumb extended in the direction of the electron flow (current) (- to +), your fingers will point in the direction of the magnetic lines of force. Now apply this rule to figure 1-2. Note that your fingers point in the direction that the north pole of the compass points when it is placed in the magnetic field surrounding the wire.

An arrow is generally used in electrical diagrams to denote the direction of current in a length of wire (see figure 1-3(A)). Where a cross section of a wire is shown, an end view of the arrow is used. A cross-sectional view of a conductor that is carrying current toward the observer is illustrated in figure 1-3(B). Notice that the direction of current is indicated by a dot, representing the head of the arrow. A conductor that is carrying current away from the observer is illustrated in figure 1-3(C). Note that the direction of current is indicated by a cross, representing the tail of the arrow. Also note that the magnetic field around a current-carrying conductor is perpendicular to the conductor, and that the magnetic lines of force are equal along all parts of the conductor.

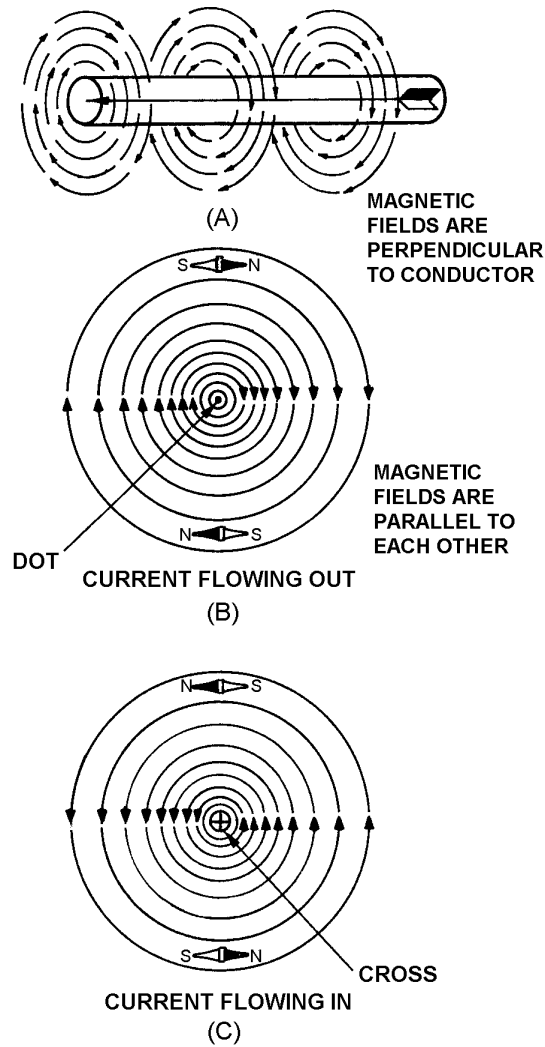
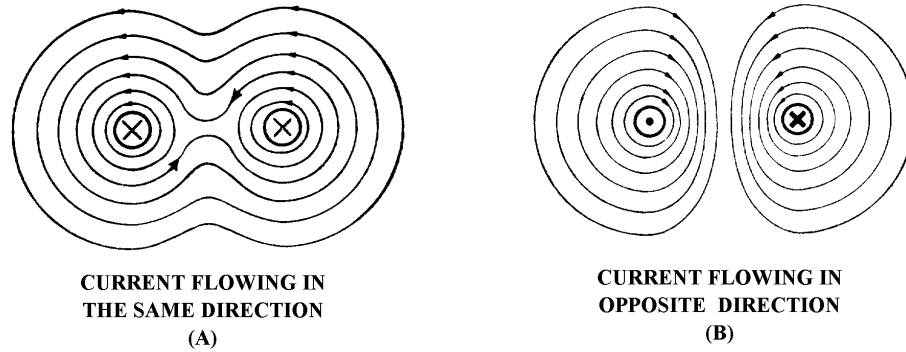

Figure 1-3.—Magnetic field around a current-carrying conductor, detailed view.

When two adjacent parallel conductors are carrying current in the same direction, the magnetic lines of force combine and increase the strength of the field around the conductors, as shown in figure 1-4(A). Two parallel conductors carrying currents in opposite directions are shown in figure 1-4(B). Note that the field around one conductor is opposite in direction to the field around the other conductor. The resulting lines of force oppose each other in the space between the wires, thus deforming the field around each conductor. This means that if two parallel and adjacent conductors are carrying currents in the same direction, the fields about the two conductors aid each other. Conversely, if the two conductors are carrying currents in opposite directions, the fields about the conductors repel each other.



**Figure 1-4.—Magnetic field around two parallel conductors.**

- Q6. When placed in the vicinity of a current-carrying conductor, the needle of a compass becomes aligned at what angle to the conductor?*
- Q7. What is the direction of the magnetic field around a vertical conductor when (a) the current flows upward and (b) the current flows downward.*
- Q8. The "left-hand rule" for a conductor is used for what purpose*
- Q9. In what direction will the compass needle point when the compass is placed in the magnetic field surrounding a wire?*
- Q10. When two adjacent parallel wires carry current in the same direction, the magnetic field about one wire has what effect on the magnetic field about the other conductor?*
- Q11. When two adjacent parallel conductors carry current in opposite directions, the magnetic field about one conductor has what effect on the magnetic field about the other conductor?*

### **MAGNETIC FIELD OF A COIL**

Figure 1-3(A) illustrates that the magnetic field around a current-carrying wire exists at all points along the wire. Figure 1-5 illustrates that when a straight wire is wound around a core, it forms a coil and that the magnetic field about the core assumes a different shape. Figure 1-5(A) is actually a partial cutaway view showing the construction of a simple coil. Figure 1-5(B) shows a cross-sectional view of the same coil. Notice that the two ends of the coil are identified as X and Y.

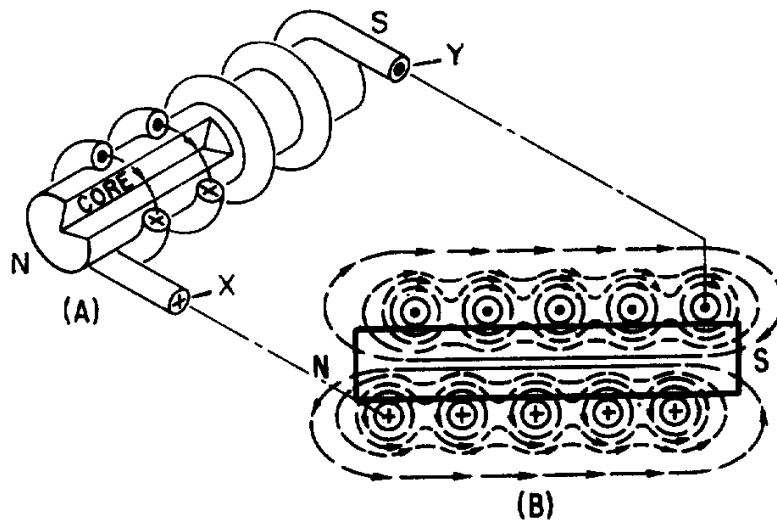

Figure 1-5.—Magnetic field produced by a current-carrying coil.

When current is passed through the coil, the magnetic field about each turn of wire links with the fields of the adjacent turns. (See figure 1-4(A)). The combined influence of all the turns produces a two-pole field similar to that of a simple bar magnet. One end of the coil is a north pole and the other end is a south pole.

### Polarity of an Electromagnetic Coil

Figure 1-2 shows that the direction of the magnetic field around a straight wire depends on the direction of current in that wire. Thus, a reversal of current in a wire causes a reversal in the direction of the magnetic field that is produced. It follows that a reversal of the current in a coil also causes a reversal of the two-pole magnetic field about the coil.

When the direction of the current in a coil is known, you can determine the magnetic polarity of the coil by using the **LEFT-HAND RULE FOR COILS**. This rule, illustrated in figure 1-6, is stated as follows:

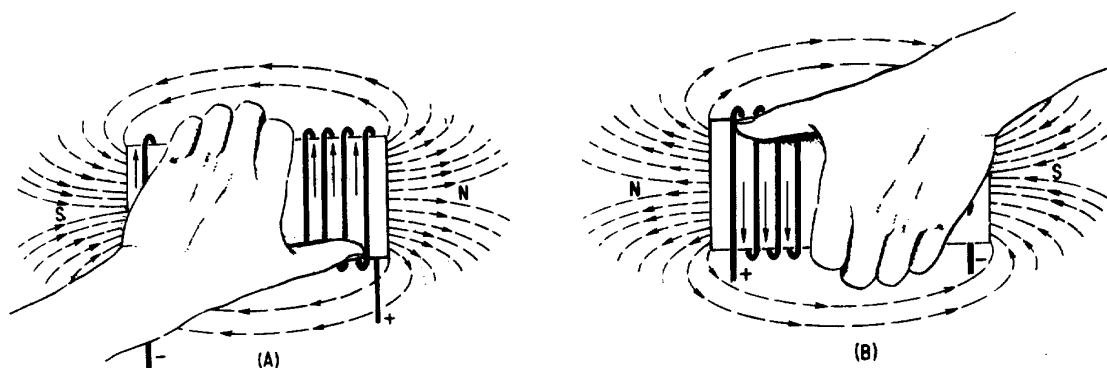

Figure 1-6.—Left-hand rule for coils.

Grasp the coil in your left hand, with your fingers "wrapped around" in the direction of the electron current flow. Your thumb will then point toward the north pole of the coil.

## Strength of an Electromagnetic Field

The strength or intensity of a coil's magnetic field depends on a number of factors. The main ones are listed below and will be discussed again later.

- The number of turns of wire in the coil.
- The amount of current flowing in the coil.
- The ratio of the coil length to the coil width.
- The type of material in the core.

## Losses in an Electromagnetic Field

When current flows in a conductor, the atoms in the conductor all line up in a definite direction, producing a magnetic field. When the direction of the current changes, the direction of the atoms' alignment also changes, causing the magnetic field to change direction. To reverse all the atoms requires that power be expended, and this power is lost. This loss of power (in the form of heat) is called HYSTERESIS LOSS. Hysteresis loss is common to all ac equipment; however, it causes few problems except in motors, generators, and transformers. When these devices are discussed later in this module, hysteresis loss will be covered in more detail.

*Q12. What is the shape of the magnetic field that exists around (a) a straight conductor and (b) a coil?*

*Q13. What happens to the two-pole field of a coil when the current through the coil is reversed?*

*Q14. What rule is used to determine the polarity of a coil when the direction of the electron current flow in the coil is known?*

*Q15. State the rule whose purpose is described in Q14.*

## BASIC AC GENERATION

From the previous discussion you learned that a current-carrying conductor produces a magnetic field around itself. In module 1, under producing a voltage (emf) using magnetism, you learned how a changing magnetic field produces an emf in a conductor. That is, if a conductor is placed in a magnetic field, and either the field or the conductor moves, an emf is induced in the conductor. This effect is called electromagnetic induction.

### CYCLE

Figures 1-7 and 1-8 show a suspended loop of wire (conductor) being rotated (moved) in a clockwise direction through the magnetic field between the poles of a permanent magnet. For ease of explanation, the loop has been divided into a dark half and light half. Notice in (A) of the figure that the dark half is moving along (parallel to) the lines of force. Consequently, it is cutting NO lines of force. The same is true of the light half, which is moving in the opposite direction. Since the conductors are cutting no lines of force, no emf is induced. As the loop rotates toward the position shown in (B), it cuts more and more lines of force per second (inducing an ever-increasing voltage) because it is cutting more directly across the field (lines of force). At (B), the conductor is shown completing one-quarter of a complete revolution, or  $90^\circ$ , of a complete circle. Because the conductor is now cutting directly across the field, the voltage

induced in the conductor is maximum. When the value of induced voltage at various points during the rotation from (A) to (B) is plotted on a graph (and the points connected), a curve appears as shown below.

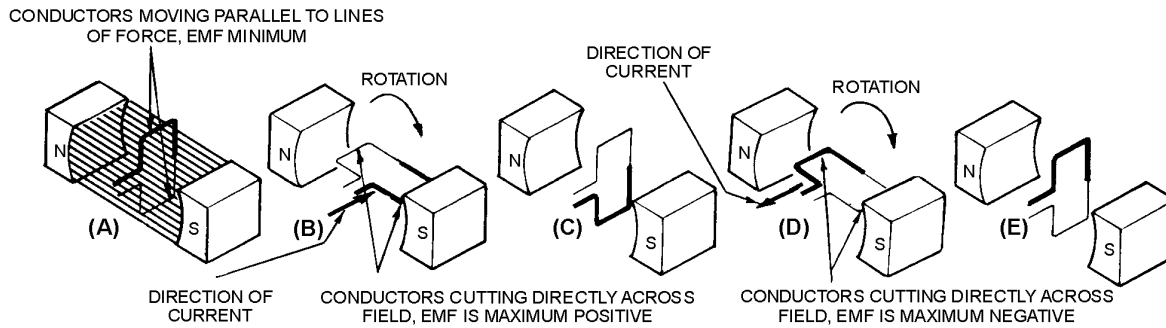

**Figure 1-7.—Simple alternating-current generator.**

As the loop continues to be rotated toward the position shown below in (C), it cuts fewer and fewer lines of force. The induced voltage decreases from its peak value. Eventually, the loop is once again moving in a plane parallel to the magnetic field, and no emf is induced in the conductor.

The loop has now been rotated through half a circle (one alternation or  $180^\circ$ ). If the preceding quarter-cycle is plotted, it appears as shown below.

When the same procedure is applied to the second half of rotation ( $180^\circ$  through  $360^\circ$ ), the curve appears as shown below. Notice the only difference is in the polarity of the induced voltage. Where previously the polarity was positive, it is now negative.

The sine curve shows the value of induced voltage at each instant of time during rotation of the loop. Notice that this curve contains  $360^\circ$ , or two alternations. TWO ALTERNATIONS represent ONE complete CYCLE of rotation.

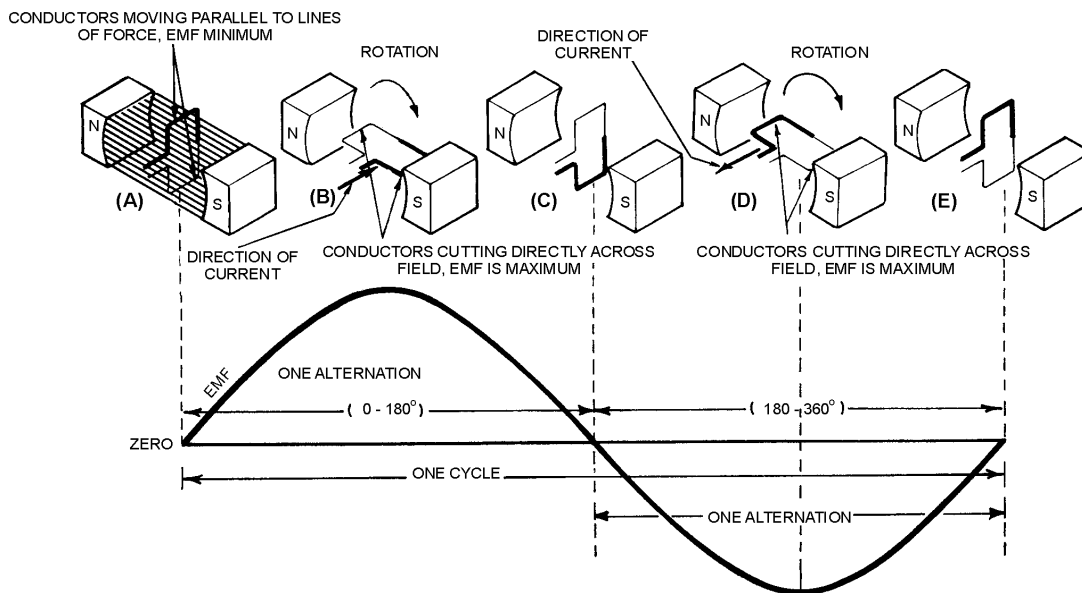

**Figure 1-8.—Basic alternating-current generator.**

Assuming a closed path is provided across the ends of the conductor loop, you can determine the direction of current in the loop by using the **LEFT-HAND RULE FOR GENERATORS**. Refer to figure 1-9. The left-hand rule is applied as follows: First, place your left hand on the illustration with the fingers as shown. Your **THUMB** will now point in the direction of rotation (relative movement of the wire to the magnetic field); your **FOREFINGER** will point in the direction of magnetic flux (north to south); and your **MIDDLE FINGER** (pointing out of the paper) will point in the direction of electron current flow.

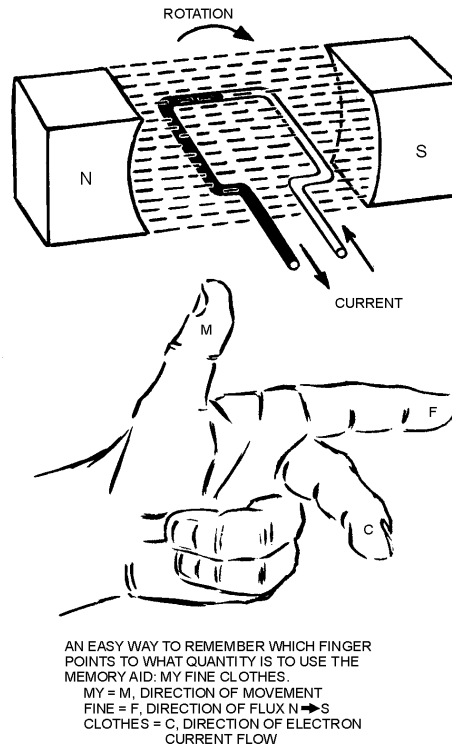

**Figure 1-9.—Left-hand rule for generators.**

By applying the left-hand rule to the dark half of the loop in (B) in figure 1-8, you will find that the current flows in the direction indicated by the heavy arrow. Similarly, by using the left-hand rule on the light half of the loop, you will find that current therein flows in the opposite direction. The two induced voltages in the loop add together to form one total emf. It is this emf which causes the current in the loop.

When the loop rotates to the position shown in (D) of figure 1-8, the action reverses. The dark half is moving up instead of down, and the light half is moving down instead of up. By applying the left-hand rule once again, you will see that the total induced emf and its resulting current have reversed direction. The voltage builds up to maximum in this new direction, as shown by the sine curve in figure 1-8. The loop finally returns to its original position (E), at which point voltage is again zero. The sine curve represents one complete cycle of voltage generated by the rotating loop. All the illustrations used in this chapter show the wire loop moving in a clockwise direction. In actual practice, the loop can be moved clockwise or counterclockwise. Regardless of the direction of movement, the left-hand rule applies.

If the loop is rotated through 360° at a steady rate, and if the strength of the magnetic field is uniform, the voltage produced is a sine wave of voltage, as indicated in figure 1-9. Continuous rotation of the loop will produce a series of sine-wave voltage cycles or, in other words, an ac voltage.

As mentioned previously, the cycle consists of two complete alternations in a period of time. Recently the HERTZ (Hz) has been designated to indicate one cycle per second. If ONE CYCLE PER SECOND is ONE HERTZ, then 100 cycles per second are equal to 100 hertz, and so on. Throughout the NEETS, the term cycle is used when no specific time element is involved, and the term hertz (Hz) is used when the time element is measured in seconds.

*Q16. When a conductor is rotated in a magnetic field, at what points in the cycle is emf (a) at maximum amplitude and (b) at minimum amplitude?*

*Q17. One cycle is equal to how many degrees of rotation of a conductor in a magnetic field?*

*Q18. State the left-hand rule used to determine the direction of current in a generator.*

*Q19. How is an ac voltage produced by an ac generator?*

## **FREQUENCY**

If the loop in the figure 1-8 (A) makes one complete revolution each second, the generator produces one complete cycle of ac during each second (1 Hz). Increasing the number of revolutions to two per second will produce two complete cycles of ac per second (2 Hz). The number of complete cycles of alternating current or voltage completed each second is referred to as the FREQUENCY. Frequency is always measured and expressed in hertz.

Alternating-current frequency is an important term to understand since most ac electrical equipments require a specific frequency for proper operation.

*Q20. Define Frequency.*

## **PERIOD**

An individual cycle of any sine wave represents a definite amount of TIME. Notice that figure 1-10 shows 2 cycles of a sine wave which has a frequency of 2 hertz (Hz). Since 2 cycles occur each second, 1 cycle must require one-half second of time. The time required to complete one cycle of a waveform is called the PERIOD of the wave. In figure 1-10, the period is one-half second. The relationship between time (t) and frequency (f) is indicated by the formulas

$$t = \frac{1}{f} \quad \text{and} \quad f = \frac{1}{t}$$

where t = period in seconds and  
f = frequency in hertz

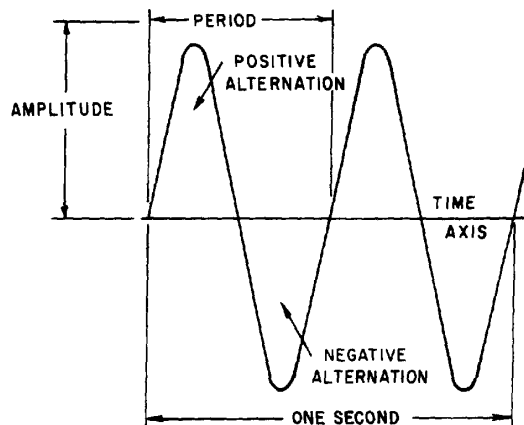

Figure 1-10.—Period of a sine wave.

Each cycle of the sine wave shown in figure 1-10 consists of two identically shaped variations in voltage. The variation which occurs during the time the voltage is positive is called the **POSITIVE ALTERNATION**. The variation which occurs during the time the voltage is negative is called the **NEGATIVE ALTERNATION**. In a sine wave, these two alternations are identical in size and shape, but opposite in polarity.

The distance from zero to the maximum value of each alternation is called the **AMPLITUDE**. The amplitude of the positive alternation and the amplitude of the negative alternation are the same.

### WAVELENGTH

The time it takes for a sine wave to complete one cycle is defined as the period of the waveform. The distance traveled by the sine wave during this period is referred to as **WAVELENGTH**. Wavelength, indicated by the symbol  $\lambda$  (Greek lambda), is the distance along the waveform from one point to the same point on the next cycle. You can observe this relationship by examining figure 1-11. The point on the waveform that measurement of wavelength begins is not important as long as the distance is measured to the same point on the next cycle (see figure 1-12).

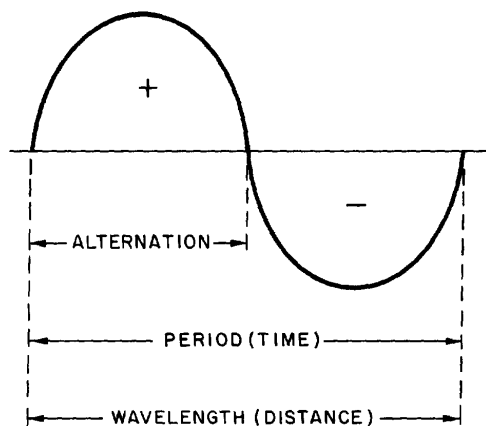

Figure 1-11.—Wavelength.

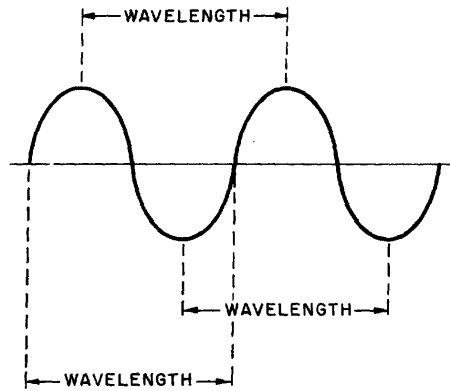

Figure 1-12.—Wavelength measurement.

- Q21. What term is used to indicate the time of one complete cycle of a waveform?
- Q22. What is a positive alternation?
- Q23. What do the period and the wavelength of a sine wave measure, respectively?

### ALTERNATING CURRENT VALUES

In discussing alternating current and voltage, you will often find it necessary to express the current and voltage in terms of MAXIMUM or PEAK values, PEAK-to-PEAK values, EFFECTIVE values, AVERAGE values, or INSTANTANEOUS values. Each of these values has a different meaning and is used to describe a different amount of current or voltage.

#### PEAK AND PEAK-TO-PEAK VALUES

Refer to figure 1-13. Notice it shows the positive alternation of a sine wave (a half-cycle of ac) and a dc waveform that occur simultaneously. Note that the dc starts and stops at the same moment as does the positive alternation, and that both waveforms rise to the same maximum value. However, the dc values are greater than the corresponding ac values at all points except the point at which the positive alternation passes through its maximum value. At this point the dc and ac values are equal. This point on the sine wave is referred to as the maximum or peak value.

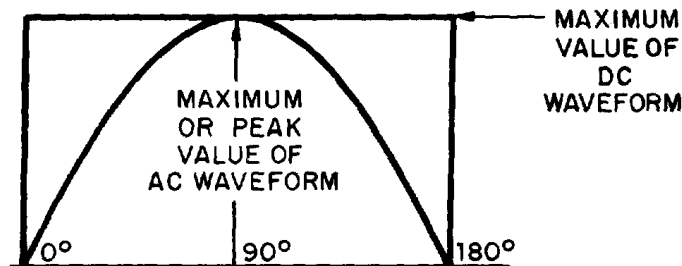

Figure 1-13.—Maximum or peak value.

During each complete cycle of ac there are always two maximum or peak values, one for the positive half-cycle and the other for the negative half-cycle. The difference between the peak positive value and the peak negative value is called the peak-to-peak value of the sine wave. This value is twice the maximum or peak value of the sine wave and is sometimes used for measurement of ac voltages. Note the difference between peak and peak-to-peak values in figure 1-14. Usually alternating voltage and current are expressed in EFFECTIVE VALUES (a term you will study later) rather than in peak-to-peak values.

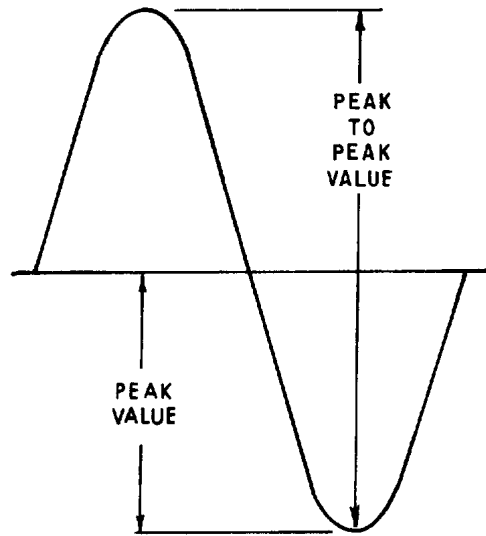

Figure 1-14.—Peak and peak-to-peak values.

Q24. What is meant by peak and peak-to-peak values of ac?

Q25. How many times is the maximum or peak value of emf or current reached during one cycle of ac?

### INSTANTANEOUS VALUE

The INSTANTANEOUS value of an alternating voltage or current is the value of voltage or current at one particular instant. The value may be zero if the particular instant is the time in the cycle at which the polarity of the voltage is changing. It may also be the same as the peak value, if the selected instant is the time in the cycle at which the voltage or current stops increasing and starts decreasing. There are actually an infinite number of instantaneous values between zero and the peak value.

### AVERAGE VALUE

The AVERAGE value of an alternating current or voltage is the average of ALL the INSTANTANEOUS values during ONE alternation. Since the voltage increases from zero to peak value and decreases back to zero during one alternation, the average value must be some value between those two limits. You could determine the average value by adding together a series of instantaneous values of the alternation (between  $0^\circ$  and  $180^\circ$ ), and then dividing the sum by the number of instantaneous values used. The computation would show that one alternation of a sine wave has an average value equal to 0.636 times the peak value. The formula for average voltage is

$$E_{\text{avg}} = 0.636 \times E_{\text{max}}$$

where  $E_{\text{avg}}$  is the average voltage of one alternation, and  $E_{\text{max}}$  is the maximum or peak voltage. Similarly, the formula for average current is

$$I_{\text{avg}} = 0.636 \times I_{\text{max}}$$

where  $I_{\text{avg}}$  is the average current in one alternation, and  $I_{\text{max}}$  is the maximum or peak current.

Do not confuse the above definition of an average value with that of the average value of a complete cycle. Because the voltage is positive during one alternation and negative during the other alternation, the average value of the voltage values occurring during the complete cycle is zero.

- Q26. *If any point on a sine wave is selected at random and the value of the current or voltage is measured at that one particular moment, what value is being measured?*
- Q27. *What value of current or voltage is computed by averaging all of the instantaneous values during the negative alternation of a sine wave?*
- Q28. *What is the average value of all of the instantaneous currents or voltages occurring during one complete cycle of a sine wave?*
- Q29. *What mathematical formulas are used to find the average value of current and average value of voltage of a sine wave?*
- Q30. *If  $E_{\text{max}}$  is 115 volts, what is  $E_{\text{avg}}$ ?*
- Q31. *If  $I_{\text{avg}}$  is 1.272 ampere, what is  $I_{\text{max}}$ ?*

### EFFECTIVE VALUE OF A SINE WAVE

$E_{\text{max}}$ ,  $E_{\text{avg}}$ ,  $I_{\text{max}}$ , and  $I_{\text{avg}}$  are values used in ac measurements. Another value used is the EFFECTIVE value of ac. This is the value of alternating voltage or current that will have the same effect on a resistance as a comparable value of direct voltage or current will have on the same resistance.

In an earlier discussion you were told that when current flows in a resistance, heat is produced. When direct current flows in a resistance, the amount of electrical power converted into heat equals  $I^2R$  watts. However, since an alternating current having a maximum value of 1 ampere does not maintain a constant value, the alternating current will not produce as much heat in the resistance as will a direct current of 1 ampere.

Figure 1-15 compares the heating effect of 1 ampere of dc to the heating effect of 1 ampere of ac.

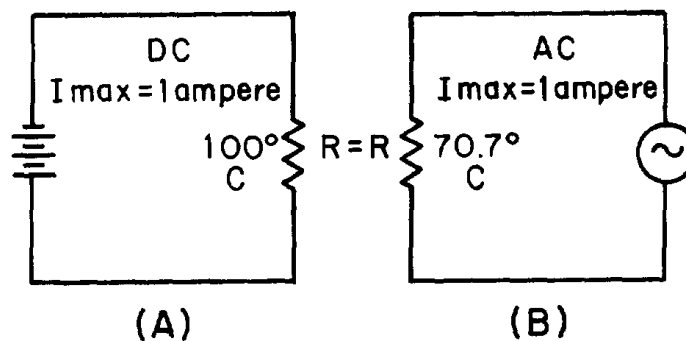

Figure 1-15.—Heating effect of ac and dc.

Examine views A and B of figure 1-15 and notice that the heat (70.7° C) produced by 1 ampere of alternating current (that is, an ac with a maximum value of 1 ampere) is only 70.7 percent of the heat (100° C) produced by 1 ampere of direct current. Mathematically,

$$\frac{\begin{array}{l} \text{The heating effect} \\ \text{of 1 maximum} \\ \text{a. c. ampere} \end{array}}{\begin{array}{l} \text{The heating effect} \\ \text{of 1 maximum} \\ \text{d. c. ampere} \end{array}} = \frac{70.7^\circ \text{ C}}{100^\circ \text{ C}} = 0.707$$

Therefore, for effective value of ac ( $I_{\text{eff}} = 0.707 \times I_{\text{max}}$ ).

The rate at which heat is produced in a resistance forms a convenient basis for establishing an effective value of alternating current, and is known as the "heating effect" method. An alternating current is said to have an effective value of one ampere when it produces heat in a given resistance at the same rate as does one ampere of direct current.

You can compute the effective value of a sine wave of current to a fair degree of accuracy by taking equally-spaced instantaneous values of current along the curve and extracting the square root of the average of the sum of the squared values.

For this reason, the effective value is often called the "root-mean-square" (rms) value. Thus,

$$I_{\text{eff}} = \sqrt{\text{Average of the sum of the squares of } I_{\text{inst}}}$$

Stated another way, the effective or rms value ( $I_{\text{eff}}$ ) of a sine wave of current is 0.707 times the maximum value of current ( $I_{\text{max}}$ ). Thus,  $I_{\text{eff}} = 0.707 \times I_{\text{max}}$ . When  $I_{\text{eff}}$  is known, you can find  $I_{\text{max}}$  by using the formula  $I_{\text{max}} = 1.414 \times I_{\text{eff}}$ . You might wonder where the constant 1.414 comes from. To find out, examine figure 1-15 again and read the following explanation. Assume that the dc in figure 1-15(A) is maintained at 1 ampere and the resistor temperature at 100° C. Also assume that the ac in figure 1-15(B) is increased until the temperature of the resistor is 100° C. At this point it is found that a maximum ac value of 1.414 amperes is required in order to have the same heating effect as direct current. Therefore, in the ac circuit the maximum current required is 1.414 times the effective current. It is important for you to remember the above relationship and that the effective value ( $I_{\text{eff}}$ ) of any sine wave of current is always 0.707 times the maximum value ( $I_{\text{max}}$ ).

Since alternating current is caused by an alternating voltage, the ratio of the effective value of voltage to the maximum value of voltage is the same as the ratio of the effective value of current to the maximum value of current. Stated another way, the effective or rms value ( $E_{\text{eff}}$ ) of a sine-wave of voltage is 0.707 times the maximum value of voltage ( $E_{\text{max}}$ ),

Thus,

$$E_{\text{eff}} = \sqrt{\text{Average of the sum of the squares of } E_{\text{inst}}}$$

or,

$$E_{\text{eff}} = 0.707 \times E_{\text{max}}$$

and,

$$E_{\text{max}} = 1.414 \times E_{\text{eff}}$$

When an alternating current or voltage value is specified in a book or on a diagram, the value is an effective value unless there is a definite statement to the contrary. Remember that all meters, unless marked to the contrary, are calibrated to indicate effective values of current and voltage.

Problem: A circuit is known to have an alternating voltage of 120 volts and a peak or maximum current of 30 amperes. What are the peak voltage and effective current values?

Given:  $E_s = 120 \text{ V}$   
 $E_{\text{max}} = 30 \text{ A}$

Solution:  $E_{\text{max}} = 1.414 \times E_{\text{eff}}$   
 $E_{\text{max}} = 1.414 \times 120 \text{ volts}$   
 $E_{\text{max}} = 169.68 \text{ volts}$   
 $I_{\text{eff}} = 0.707 \times I_{\text{max}}$   
 $I_{\text{eff}} = 0.707 \times 30 \text{ amperes}$   
 $I_{\text{eff}} = 21.21 \text{ amperes}$

Figure 1-16 shows the relationship between the various values used to indicate sine-wave amplitude. Review the values in the figure to ensure you understand what each value indicates.

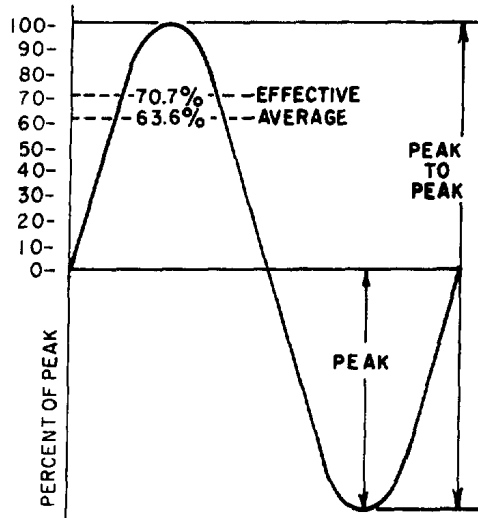

Figure 1-16.—Various values used to indicate sine-wave amplitude.

- Q32. What is the most convenient basis for comparing alternating and direct voltages and currents?
- Q33. What value of ac is used as a comparison to dc?
- Q34. What is the formula for finding the effective value of an alternating current?
- Q35. If the peak value of a sine wave is 1,000 volts, what is the effective ( $E_{eff}$ ) value?
- Q36. If  $I_{eff} = 4.25$  ampere, what is  $I_{max}$ ?

### SINE WAVES IN PHASE

When a sine wave of voltage is applied to a resistance, the resulting current is also a sine wave. This follows Ohm's law which states that current is directly proportional to the applied voltage. Now examine figure 1-17. Notice that the sine wave of voltage and the resulting sine wave of current are superimposed on the same time axis. Notice also that as the voltage increases in a positive direction, the current increases along with it, and that when the voltage reverses direction, the current also reverses direction. When two sine waves, such as those represented by figure 1-17, are precisely in step with one another, they are said to be IN PHASE. To be in phase, the two sine waves must go through their maximum and minimum points at the same time and in the same direction.

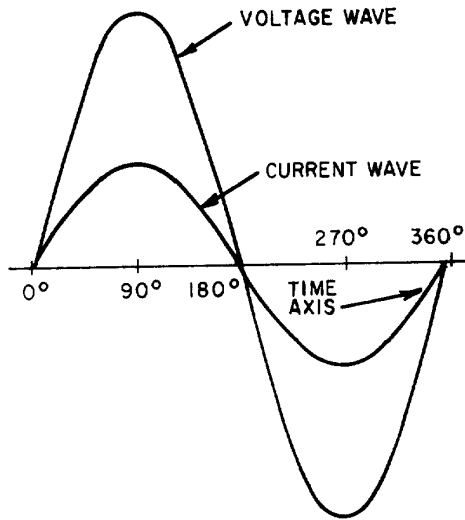

Figure 1-17.—Voltage and current waves in phase.

In some circuits, several sine waves can be in phase with each other. Thus, it is possible to have two or more voltage drops in phase with each other and also be in phase with the circuit current.

### SINE WAVES OUT OF PHASE

Figure 1-18 shows voltage wave  $E_1$  which is considered to start at  $0^\circ$  (time one). As voltage wave  $E_1$  reaches its positive peak, voltage wave  $E_2$  starts its rise (time two). Since these voltage waves do not go through their maximum and minimum points at the same instant of time, a PHASE DIFFERENCE exists between the two waves. The two waves are said to be OUT OF PHASE. For the two waves in figure 1-18 the phase difference is  $90^\circ$ .

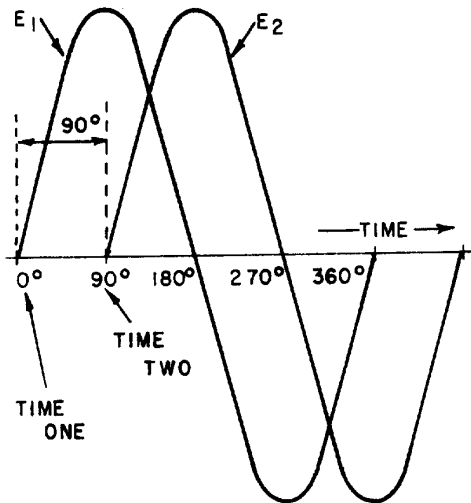

Figure 1-18.—Voltage waves  $90^\circ$  out of phase.

To further describe the phase relationship between two sine waves, the terms LEAD and LAG are used. The amount by which one sine wave leads or lags another sine wave is measured in degrees. Refer again to figure 1-18. Observe that wave  $E_2$  starts  $90^\circ$  later in time than does wave  $E_1$ . You can also describe this relationship by saying that wave  $E_1$  leads wave  $E_2$  by  $90^\circ$ , or that wave  $E_2$  lags wave  $E_1$  by  $90^\circ$ . (Either statement is correct; it is the phase relationship between the two sine waves that is important.)

It is possible for one sine wave to lead or lag another sine wave by any number of degrees, except  $0^\circ$  or  $360^\circ$ . When the latter condition exists, the two waves are said to be in phase. Thus, two sine waves that differ in phase by  $45^\circ$  are actually out of phase with each other, whereas two sine waves that differ in phase by  $360^\circ$  are considered to be in phase with each other.

A phase relationship that is quite common is shown in figure 1-19. Notice that the two waves illustrated differ in phase by  $180^\circ$ . Notice also that although the waves pass through their maximum and minimum values at the same time, their instantaneous voltages are always of opposite polarity. If two such waves exist across the same component, and the waves are of equal amplitude, they cancel each other. When they have different amplitudes, the resultant wave has the same polarity as the larger wave and has an amplitude equal to the difference between the amplitudes of the two waves.

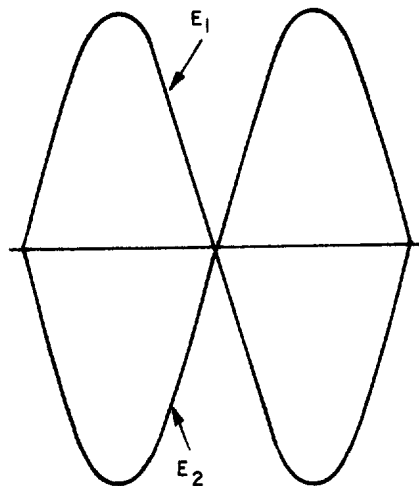

Figure 1-19.—Voltage waves  $180^\circ$  out of phase.

To determine the phase difference between two sine waves, locate the points on the time axis where the two waves cross the time axis traveling in the same direction. The number of degrees between the crossing points is the phase difference. The wave that crosses the axis at the later time (to the right on the time axis) is said to lag the other wave.

Q37. *When are the voltage wave and the current wave in a circuit considered to be in phase?*

Q38. *When are two voltage waves considered to be out of phase?*

Q39. *What is the phase relationship between two voltage waves that differ in phase by  $360^\circ$ ?*

Q40. *How do you determine the phase difference between two sine waves that are plotted on the same graph?*

## OHM'S LAW IN AC CIRCUITS

Many ac circuits contain resistance only. The rules for these circuits are the same rules that apply to dc circuits. Resistors, lamps, and heating elements are examples of resistive elements. When an ac circuit contains only resistance, Ohm's Law, Kirchhoff's Law, and the various rules that apply to voltage, current, and power in a dc circuit also apply to the ac circuit. The Ohm's Law formula for an ac circuit can be stated as

$$I_{\text{eff}} = \frac{E_{\text{eff}}}{R} \text{ or } I = \frac{E}{R}$$

Remember, unless otherwise stated, all ac voltage and current values are given as effective values. The formula for Ohm's Law can also be stated as

$$I_{\text{avg}} = \frac{E_{\text{avg}}}{R} \text{ or } I_{\text{max}} = \frac{E_{\text{max}}}{R}$$
$$I_{\text{peak-to-peak}} = \frac{E_{\text{peak-to-peak}}}{R}$$

The important thing to keep in mind is: Do Not mix ac values. When you solve for effective values, all values you use in the formula must be effective values. Similarly, when you solve for average values, all values you use must be average values. This point should be clearer after you work the following problem: A series circuit consists of two resistors ( $R_1 = 5$  ohms and  $R_2 = 15$  ohms) and an alternating voltage source of 120 volts. What is  $I_{\text{avg}}$ ?

Given :

$$R_1 = 5 \text{ ohms}$$
$$R_2 = 15 \text{ ohms}$$
$$E_s = 120 \text{ ohms}$$

Solution: First solve for total resistance  $R_T$ .

$$R_T = R_1 + R_2$$
$$R_T = 5 \text{ ohms} + 15 \text{ ohms}$$
$$R_T = 20 \text{ ohms}$$

The alternating voltage is assumed to be an effective value (since it is not specified to be otherwise). Apply the Ohm's Law formula.

$$I_{\text{eff}} = \frac{E_{\text{eff}}}{R}$$

$$I_{\text{eff}} = \frac{120 \text{ volts}}{20 \text{ ohms}}$$

$$I_{\text{eff}} = 6 \text{ amperes}$$

The problem, however, asked for the average value of current ( $I_{\text{avg}}$ ). To convert the effective value of current to the average value of current, you must first determine the peak or maximum value of current,  $I_{\text{max}}$ .

$$I_{\text{max}} = 1.414 \times I_{\text{eff}}$$

$$I_{\text{max}} = 1.414 \times 6 \text{ amperes}$$

$$I_{\text{max}} = 8.484 \text{ amperes}$$

You can now find  $I_{\text{avg}}$ . Just substitute 8.484 amperes in the  $I_{\text{avg}}$  formula and solve for  $I_{\text{avg}}$ .

$$I_{\text{avg}} = 0.636 \times I_{\text{max}}$$

$$I_{\text{avg}} = 0.636 \times 8.484 \text{ amperes}$$

$$I_{\text{avg}} = 5.4 \text{ amperes (rounded off to one decimal place)}$$

Remember, you can use the Ohm's Law formulas to solve any purely resistive ac circuit problem. Use the formulas in the same manner as you would to solve a dc circuit problem.

- Q41. A series circuit consists of three resistors ( $R_1 = 10\Omega$ ,  $R_2 = 20\Omega$ ,  $R_3 = 15\Omega$ ) and an alternating voltage source of 100 volts. What is the effective value of current in the circuit?*
- Q42. If the alternating source in Q41 is changed to 200 volts peak-to-peak, what is  $I_{\text{avg}}$ ?*
- Q43. If  $E_{\text{eff}}$  is 130 volts and  $I_{\text{eff}}$  is 3 amperes, what is the total resistance ( $R_T$ ) in the circuit?*

## SUMMARY

Before going on to chapter 2, read the following summary of the material in chapter 1. This summary will reinforce what you have already learned.

**DC AND AC**—Direct current flows in one direction only, while alternating current is constantly changing in amplitude and direction.

**ADVANTAGES AND DISADVANTAGES OF AC AND DC**—Direct current has several disadvantages compared to alternating current. Direct current, for example, must be generated at the voltage level required by the load. Alternating current, however, can be generated at a high level and

stepped down at the consumer end (through the use of a transformer) to whatever voltage level is required by the load. Since power in a dc system must be transmitted at low voltage and high current levels, the  $I^2R$  power loss becomes a problem in the dc system. Since power in an ac system can be transmitted at a high voltage level and a low current level, the  $I^2R$  power loss in the ac system is much less than that in the dc system.

**VOLTAGE WAVEFORMS**—The waveform of voltage or current is a graphical picture of changes in voltage or current values over a period of time.

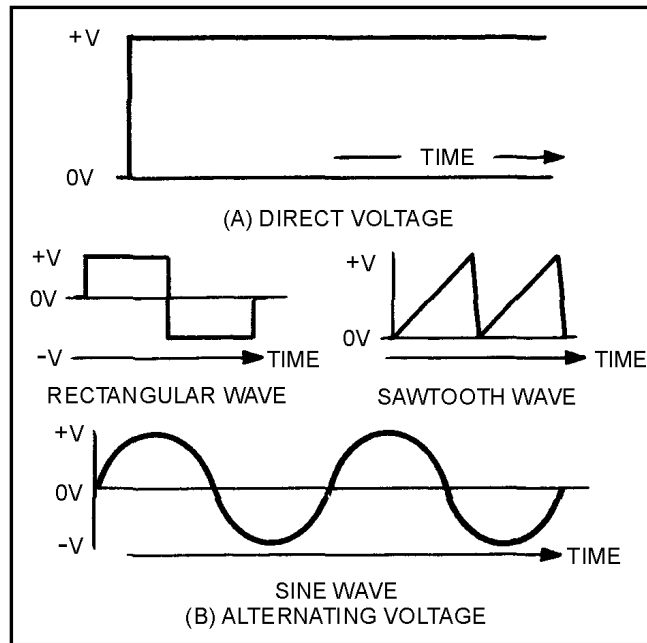

**ELECTROMAGNETISM**—When a compass is placed in the vicinity of a current-carrying conductor, the needle aligns itself at right angles to the conductor. The north pole of the compass indicates the direction of the magnetic field produced by the current. By knowing the direction of current, you can use the left-hand rule for conductors to determine the direction of the magnetic lines of force.

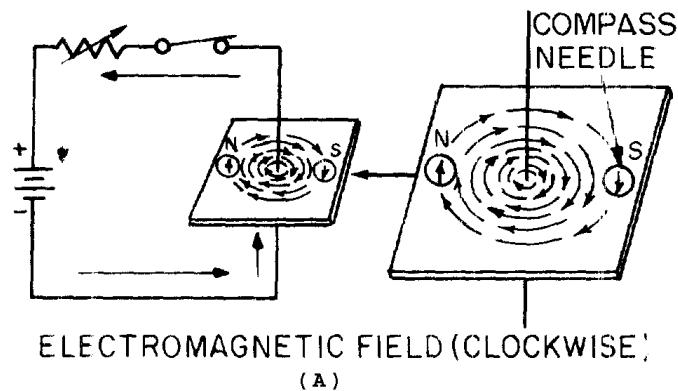

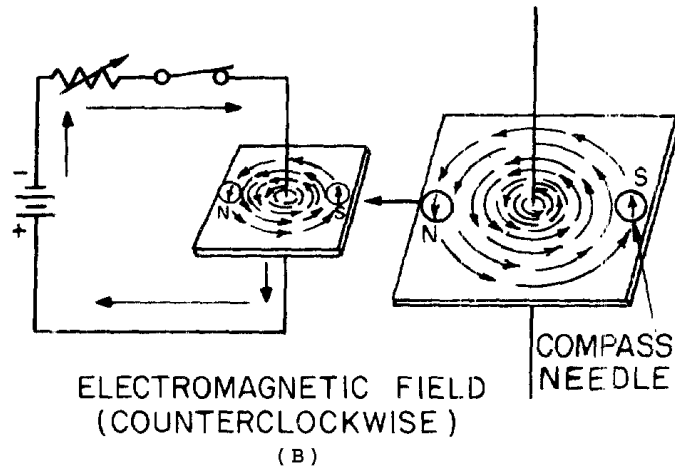

Arrows are generally used in electrical diagrams to indicate the direction of current in a wire. A cross (+) on the end of a cross-sectional view of a wire indicates that current is flowing away from you, while a dot (·) indicates that current is flowing toward you.

When two adjacent parallel conductors carry current in the same direction, the magnetic fields around the conductors aid each other. When the currents in the two conductors flow in opposite directions, the fields around the conductors oppose each other.

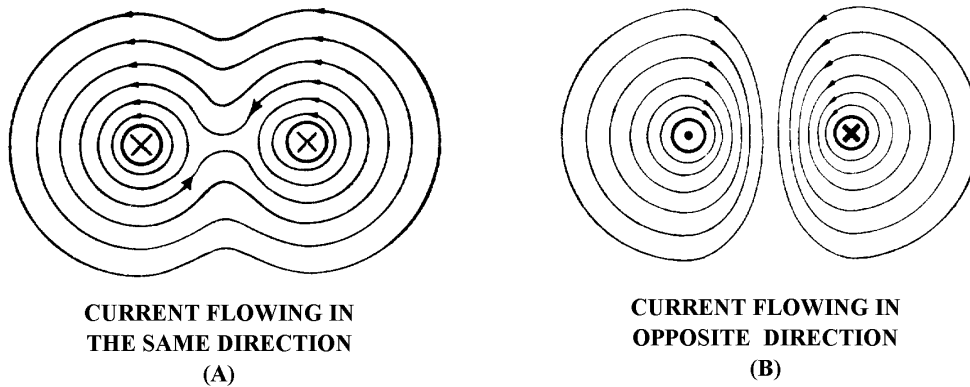

**MAGNETIC FIELD OF A COIL**—When wire is wound around a core, it forms a COIL. The magnetic fields produced when current flows in the coil combine. The combined influence of all of the fields around the turns produce a two-pole field similar to that of a simple bar magnet.

When the direction of current in the coil is reversed, the polarity of the two-pole field of the coil is reversed.

The strength of the magnetic field of the coil is dependent upon:

- The number of turns of the wire in the coil.
- The amount of current in the coil.
- The ratio of the coil length to the coil width.

- The type of material in the core.

**BASIC AC GENERATION**—When a conductor is in a magnetic field and either the field or the conductor moves, an emf (voltage) is induced in the conductor. This effect is called electromagnetic induction.

A loop of wire rotating in a magnetic field produces a voltage which constantly changes in amplitude and direction. The waveform produced is called a sine wave and is a graphical picture of alternating current (ac). One complete revolution (360°) of the conductor produces one cycle of ac. The cycle is composed of two alternations: a positive alternation and a negative alternation. One cycle of ac in one second is equal to 1 hertz (1 Hz).

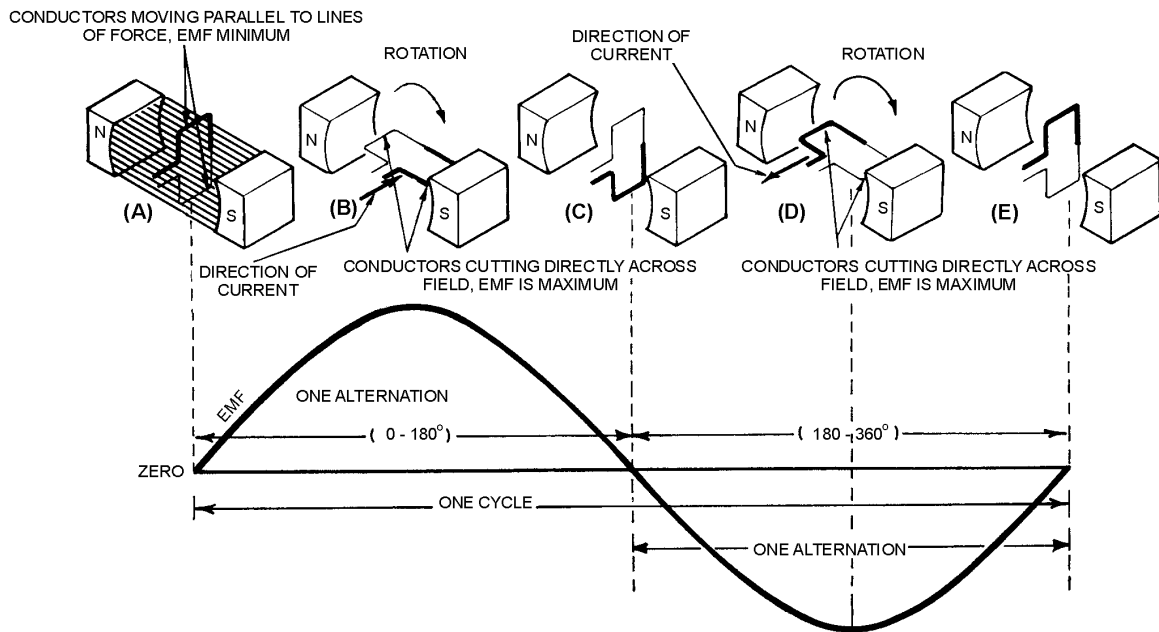

**FREQUENCY**—The number of cycles of ac per second is referred to as the FREQUENCY. AC frequency is measured in hertz. Most ac equipment is rated by frequency as well as by voltage and current.

**PERIOD**—The time required to complete one cycle of a waveform is called the PERIOD OF THE WAVE.

Each ac sine wave is composed of two alternations. The alternation which occurs during the time the sine wave is positive is called the positive alternation. The alternation which occurs during the time the sine wave is negative is called the negative alternation. In each cycle of sine wave, the two alternations are identical in size and shape, but opposite in polarity.

The period of a sine wave is inversely proportional to the frequency; e.g., the higher the frequency, the shorter the period. The mathematical relationships between time and frequency are

$$t = \frac{1}{f} \text{ and } f = \frac{1}{t}$$

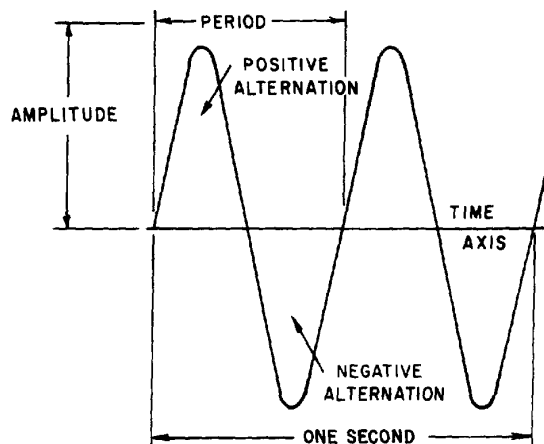

**WAVELENGTH**—The period of a sine wave is defined as the time it takes to complete one cycle. The distance the waveform covers during this period is referred to as the wavelength. Wavelength is indicated by lambda ( $\lambda$ ) and is measured from a point on a given waveform (sine wave) to the corresponding point on the next waveform.

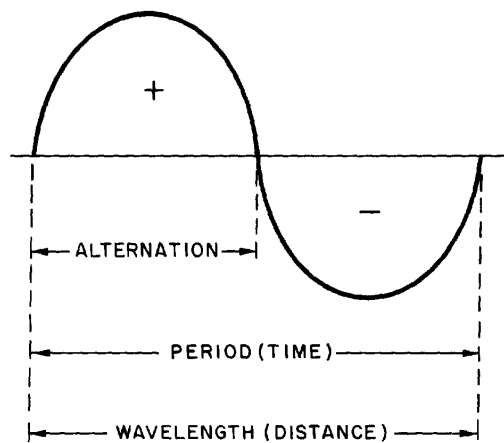

**PEAK AND PEAK-TO-PEAK VALUES**—The maximum value reached during one alternation of a sine wave is the peak value. The maximum reached during the positive alternation to the maximum value reached during the negative alternation is the peak-to-peak value. The peak-to-peak value is twice the peak value.

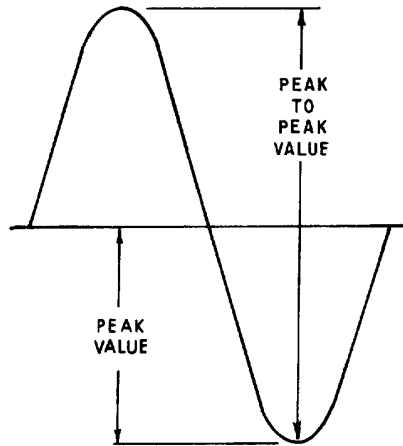

**INSTANTANEOUS VALUE**—The instantaneous value of a sine wave of alternating voltage or current is the value of voltage or current at one particular instant of time. There are an infinite number of instantaneous values between zero and the peak value.

**AVERAGE VALUE**—The average value of a sine wave of voltage or current is the average of all the instantaneous values during one alternation. The average value is equal to 0.636 of the peak value. The formulas for average voltage and average current are:

$$E_{avg} = 0.636 \times E_{max}$$

$$I_{avg} = 0.636 \times I_{max}$$

Remember: The average value ( $E_{avg}$  or  $I_{avg}$ ) is for one alternation only. The average value of a complete sine wave is zero.

**EFFECTIVE VALUE**—The effective value of an alternating current or voltage is the value of alternating current or voltage that produces the same amount of heat in a resistive component that would be produced in the same component by a direct current or voltage of the same value. The effective value of a sine wave is equal to 0.707 times the peak value. The effective value is also called the root mean square or rms value.

The term rms value is used to describe the process of determining the effective value of a sine wave by using the instantaneous value of voltage or current. You can find the rms value of a current or voltage by taking equally spaced instantaneous values on the sine wave and extracting the square root of the average of the sum of the instantaneous values. This is where the term "Root-Mean-Square" (rms) value comes from.

The formulas for effective and maximum values of voltage and current are:

$$E_{eff} = 0.707 \times E_{max}$$

$$E_{max} = 1.414 \times E_{eff}$$

$$I_{eff} = 0.707 \times I_{max}$$

$$I_{max} = 1.414 \times I_{eff}$$

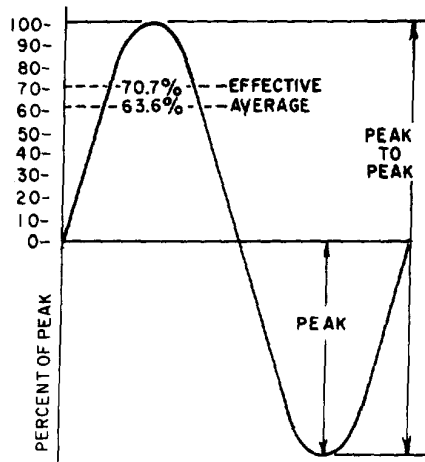

**SINE WAVES IN PHASE**—When two sine waves are exactly in step with each other, they are said to be in phase. To be in phase, both sine waves must go through their minimum and maximum points at the same time and in the same direction.

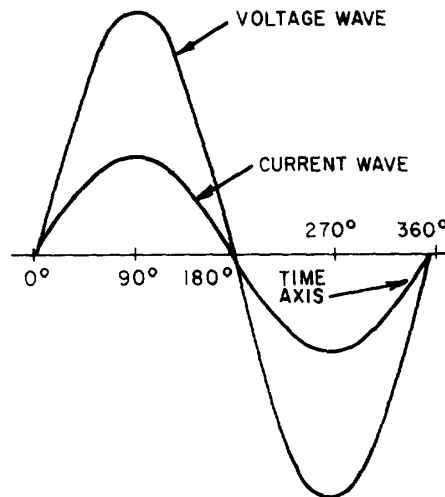

**SINE WAVES OUT OF PHASE**—When two sine waves go through their minimum and maximum points at different times, a phase difference exists between them. The two waves are said to be out of phase with each other. To describe this phase difference, the terms lead and lag are used. The wave that reaches its minimum (or maximum) value first is said to lead the other wave. The term lag is used to describe the wave that reaches its minimum (or maximum) value some time after the first wave does. When a sine wave is described as leading or lagging, the difference in degrees is usually stated. For example, wave  $E_1$  leads wave  $E_2$  by  $90^\circ$ , or wave  $E_2$  lags wave  $E_1$  by  $90^\circ$ . Remember: Two sine waves can differ by any number of degrees except  $0^\circ$  and  $360^\circ$ . Two sine waves that differ by  $0^\circ$  or by  $360^\circ$  are considered to be in phase. Two sine waves that are opposite in polarity and that differ by  $180^\circ$  are said to be out of phase, even though they go through their minimum and maximum points at the same time.

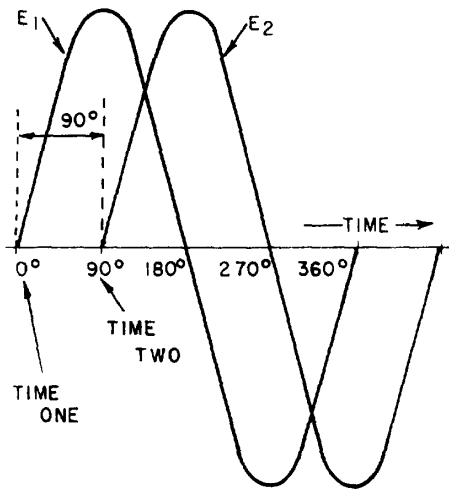

**OHM'S LAW IN AC CIRCUIT**—All dc rules and laws apply to an ac circuit that contains only resistance. The important point to remember is: Do not mix ac values. Ohm's Law formulas for ac circuits are given below:

$$I = \frac{E}{R}$$

$$I_{\text{eff}} = \frac{E_{\text{eff}}}{R}$$

$$I_{\text{avg}} = \frac{E_{\text{avg}}}{R}$$

$$I_{\text{max}} = \frac{E_{\text{max}}}{R}$$

$$I_{\text{Peak-to-Peak}} = \frac{E_{\text{Peak-to-Peak}}}{R}$$

## ANSWERS TO QUESTIONS Q1. THROUGH Q43.

- A1. *An electrical current which flows in one direction only.*
- A2. *An electrical current which is constantly varying in amplitude, and which changes direction at regular intervals.*
- A3. *The dc voltage must be generated at the level required by the load.*
- A4. *The  $I^2R$  power loss is excessive.*
- A5. *Alternating current (ac).*
- A6. *The needle aligns itself at right angles to the conductor.*
- A7. *(a) clockwise (b) counterclockwise.*
- A8. *It is used to determine the relation between the direction of the magnetic lines of force around a conductor and the direction of current through the conductor.*
- A9. *The north pole of the compass will point in the direction of the magnetic lines of force.*
- A10. *It combines with the other field.*
- A11. *It deforms the other field.*
- A12. *(a) The field consists of concentric circles in a plane perpendicular to the wire (b) the field of each turn of wire links with the fields of adjacent turns producing a two-pole field similar in shape to that of a simple bar magnet.*
- A13. *The polarity of the two-pole field reverses.*
- A14. *Use the left-hand rule for coils.*
- A15. *Grasp the coil in your left hand, with your fingers "wrapped around" in the direction of electron flow. The thumb will point toward the north pole.*
- A16. *(a) When the conductors are cutting directly across the magnetic lines of force (at the  $90^\circ$  and  $270^\circ$  points). (b) When the conductors are moving parallel to the magnetic lines of force (at the  $0^\circ$ ,  $180^\circ$ , and  $360^\circ$  points).*
- A17.  *$360^\circ$ .*
- A18. *Extend your left hand so that your thumb points in the direction of conductor movement, and your forefinger points in the direction of the magnetic flux (north to south). Now point your middle finger  $90^\circ$  from the forefinger and it will point in the direction of electron current flow in the conductor.*
- A19. *Continuous rotation of the conductor through magnetic lines of force produces a series of cycles of alternating voltage or, in other words, an alternating voltage or a sine wave of voltage.*
- A20. *Frequency is the number of complete cycles of alternating voltage or current completed each second.*

A21. *Period.*

A22. *A positive alternation is the positive variation in the voltage or current of a sine curve.*

A23. *The period measures time and the wavelength measures distance.*

A24. *The peak value is the maximum value of one alternation; the peak-to-peak value is twice the maximum or peak value.*

A25. *Twice.*

A26. *The instantaneous value ( $E_{inst}$  or  $I_{inst}$ )*

A27. *Average value ( $E_{avg}$  or  $I_{avg}$ )*

A28. *Zero*

A29.

$$I_{avg} = 0.636 \times I_{max}$$

$$E_{avg} = 0.636 \times E_{max}$$

A30.

$$E_{avg} = 0.636 \times 115 \text{ volts}$$

$$E_{avg} = 73.14 \text{ volts}$$

A31.

$$\text{If } I_{avg} = I_{max} \times 0.636, \text{ then } I_{max} = \frac{I_{avg}}{0.636}$$

Thus,

$$I_{max} = \frac{1.272}{0.636} \text{ amperes} = 2 \text{ amperes}$$

A32. *The power (heat) produced in a resistance by a dc voltage is compared to that produced in the same resistance by an ac voltage of the same peak amplitude.*

A33. *The effective value.*

A34.

$$I_{eff} = 0.707 \times I_{max}$$

A35.

$$\begin{aligned} E_{\text{eff}} &= 0.707 \times E_{\text{max}} \\ &= 0.707 \times E_{\text{max}} \\ &= 0.707 \times 1,000 \text{ volts} \\ E_{\text{eff}} &= 707 \text{ volts} \end{aligned}$$

A36.

$$\begin{aligned} I_{\text{max}} &= 1.414 \times I_{\text{eff}} \\ &= 1.414 \times 4.25 \text{ amperes} \\ &= 6 \text{ amperes.} \end{aligned}$$

*(Remember: Unless specified otherwise, the voltage or current value is always considered to be the effective value.)*

A37. *When the two waves go through their maximum and minimum points at the same time and in the same direction.*

A38. *When the waves do not go through their maximum and minimum points at the same time, a PHASE DIFFERENCE exists, and the two waves are said to be out of phase. (Two waves are also considered to be out of phase if they differ in phase by  $180^\circ$  and their instantaneous voltages are always of opposite polarity, even though both waves go through their maximum and minimum points at the same time).*

A39. *They are in phase with each other.*

A40. *Locate the points on the time axis where the two waves cross traveling in the same direction. The number of degrees between these two points is the phase difference.*

A41.

$$I_{\text{eff}} = \frac{100}{45} = 2.22 \text{ amperes}$$

A42.  $I_{\text{avg}} = 0.636 \times I_{\text{max}} = 1.41 \text{ amperes.}$

A43. *43.3 ohms.*